JUE-501 FleetBroadband



– with the new JRC JUE-501 FleetBroadband FB500 onboard communication has never been this fast

Proven antenna design

Ready for all Inmarsat FB services

Advanced integrated web interface

Single coax installation

Wide range of interfaces as standard

Features

Features

The JUE-501, the latest-generation maritime communication solution from JRC, is compactly designed, easy to install and puts high-speed connectivity right at your fingertips.



Proven antenna design

Our company's long experience of antenna design has ensured that the antenna is robust and easy to install. No gyro or GPS input is required and it benefits from having no cable under the antenna, which means there is no need for 'cable unwrap' manoeuvres to free cable that has become twisted as the device moves to locate the satellite.

Using the same cable management philosophy as other current JRC Inmarsat products, a single coax cable is used between the antenna and main unit allowing for easy installation.

These and more features make the electronics and mechanical design of the JRC JUE-500 as advanced on the inside as it is on the outside.

About FleetBroadband

Based on 3G standards, FleetBroadband provides constant, simultaneous access to voice and high-speed data, capable of supporting always-on broadband connectivity at speeds up to 432kbps and streaming IP data rate of up to 256kbps.

It allows users to send and receive SMS messages of up to 160 characters, a feature that is proven popular with crew who are familiar with texting from their GSM mobiles while on shore.

Ready for (latest) Inmarsat services:

- ✓ Non SOLAS voice distress¹
- ✓ Multi voice function¹
- ✓ Dynamic telemetry service²
- ✓ Ancillary terrestrial component
- ✓ Alphasat
- ✓ 505 emergency calling

1. Expected support end 2012.
2. Availability on request.

Interfacing

Advanced interfacing

With JRC's new JUE-501 main unit comes a whole new set of reliable interfacing, such as a dedicated non SOLAS voice distress port and an integrated WAN selector between JRC's main unit and other communication devices, which switches the unit to a secondary network when the primary network is disconnected.

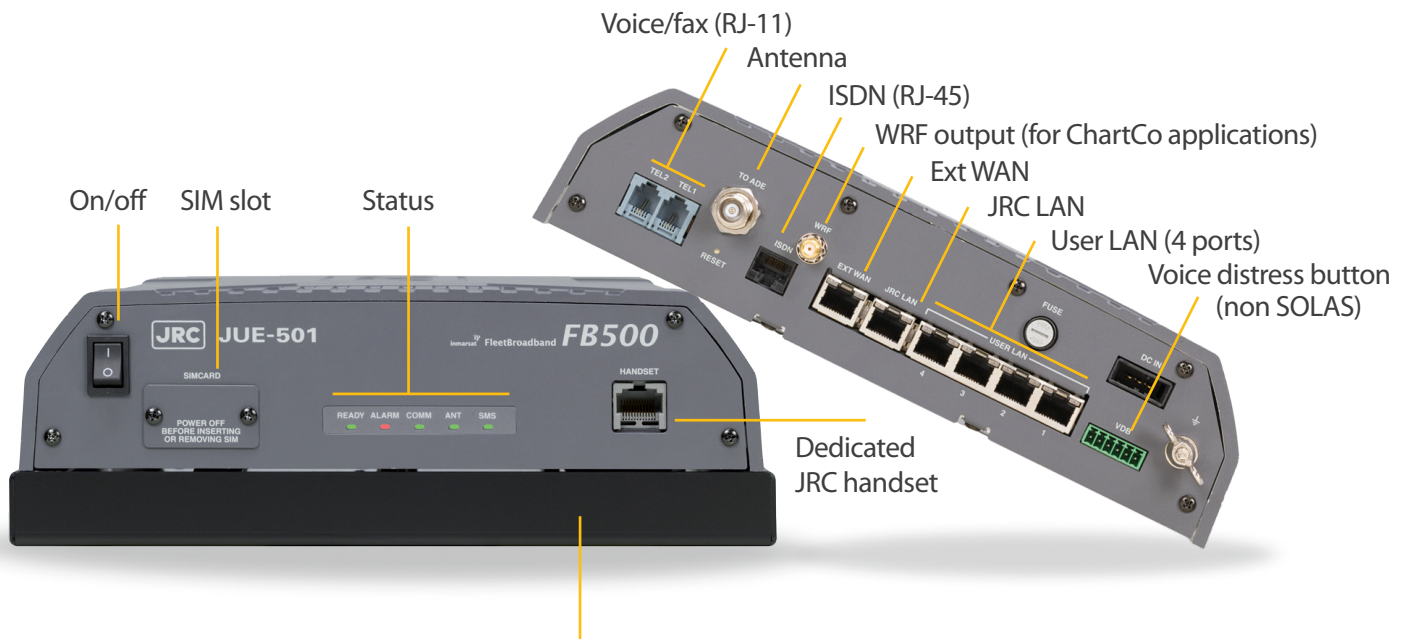

Crew installation

With crew installation possible, you will save on installation charges and time in port - while keeping the same warranty conditions as before.

Optional junction board New

In addition to the standard interface, JRC offers an optional junction board packed with a range of additional features. It has 4 telephone/fax lines (RJ-11), 4 external buzzers, 1 voice distress button, gyro and GPS input, remote power switch and multi-purpose dry contact ports.

Satellite blocking New

The JUE-501 integrates a blockage setting which allows you to register up to 6 blocking areas such as the radar mast or funnel. When the line of sight to the satellite coincides with any of the pre registered blocking areas, the operator can easily recognize that there is a blockage and can take necessary action such as course change, to restore the connection.



Remote Maintenance System (RMS) New

The JUE-501 supports RMS access via ISDN as well as over a dedicated JRC IP connection, which allows for remote maintenance of supported equipment via the Inmarsat satellite link. Additionally, JRC's new Inmarsat C model, the JUE-87, can be used to poll the status of the JUE-501 from the shore, should the ship's IP data connection be unavailable. jrceurope.com/rms

Flexibility

Advanced web interface New

The JUE-501 Inmarsat FleetBroadband comes with an advanced web interface, built in as standard. This dedicated (Windows based) user interface brings together all operations. Think of it as the hub of your system - view everything and fully manage all operations with a few clicks.

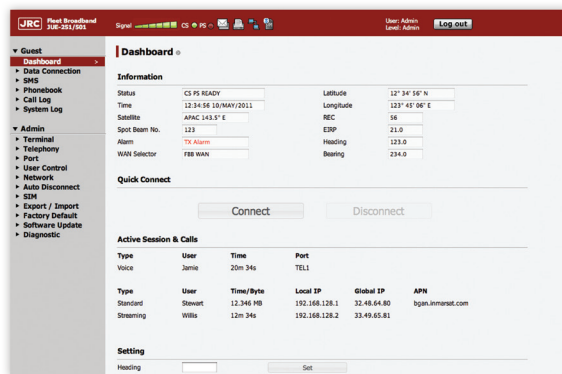

Below are just a few of the many features available:

1 by 1 NAT	Diagnostics	MAC filter	Remote activate	Usage restriction
Always active	DMZ host	Multi voice	Routing table	User control
Auto disconnect	Dynamic DHCP	PBX	SIM configure	VLAN
Blockage indication	Export	Phonebook	SMS	VPN (IPsec)
Call log	Import	Port forward	Static DHCP	WAN filter
Dashboard	IP masquerade	PPPoE	Supplementary	WAN profile
Data connection	LAN group	Proxy DNS	System log	WAN selector



Voice distress button New

The JUE-501 will support Inmarsat's voice distress service with an optional voice distress button, connected directly to the main unit. A voice distress call has the priority and pre-emption over any calls on the Inmarsat satellite network, guaranteed to get through to an appropriate Maritime Rescue Coordination Center (MRCC). The service is not currently GMDSS compliant.

What's standard?

- Antenna
- Main unit
- Handset
- Antenna cable (50 m)
- Power cable (5 m)
- Manuals
- Inspection result
- CD
- Installation parts
- Spares

What's optional?

- Antenna cable 15, 30, 35, 40, 45, 50 (std), 70, 100 m
- Junction board CQD-2243
- Power supply NBD-904
- External buzzer NCE-6824A (max 4)
- Voice distress button NQE-3301 (max 2)
- Fax (Brother FAX-2820)
- Power transformer fax DD-118525 (100V), DD-118584 (115V)
- EMC filter for fax RSHN-2003 (for 230V direct coupling)
- Telephone NQW-132B (max 6)
- Telephone junction box NQE-3058C (max 10)
- Handset extension cable 7ZCSC0291 (5 m)
- Gyro interface box NQA-2066A



Japan Radio Co., Ltd.

Weight and dimensions

Antenna

GSC-511 Weight 20 kg

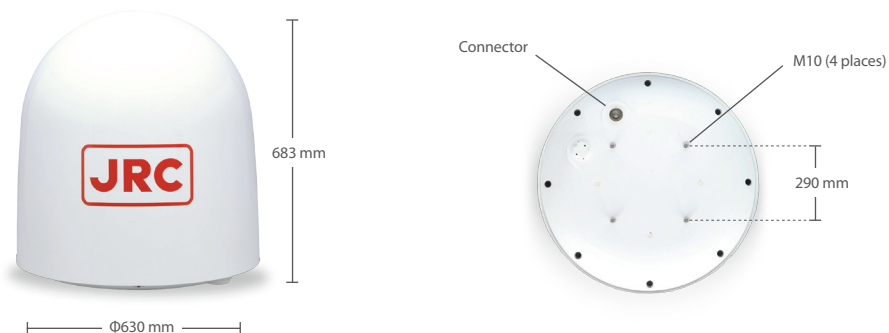

Main unit New

GSC-512 Weight 4,5 kg

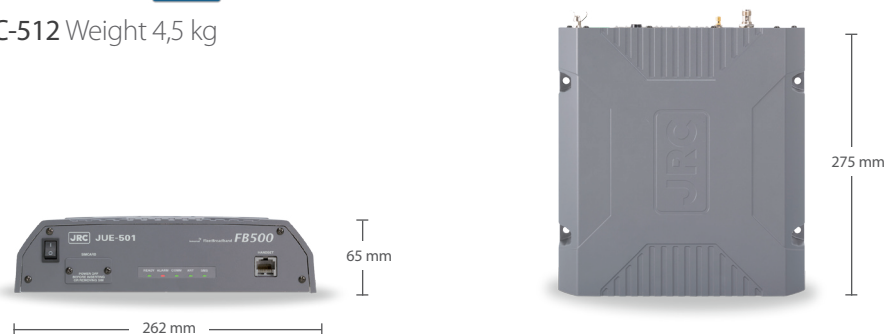

Handset

NQW-267 Weight 0,5 kg

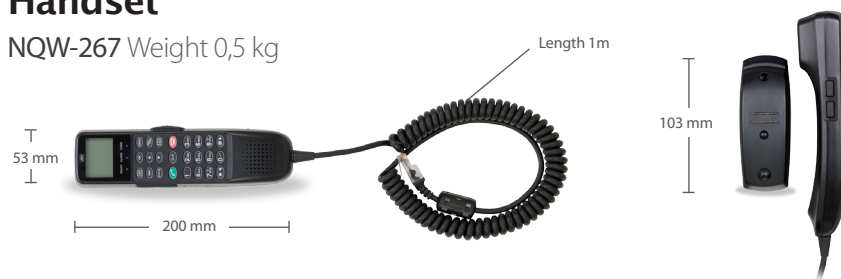

Power supply option New

NBD-904 Weight 2,6 kg

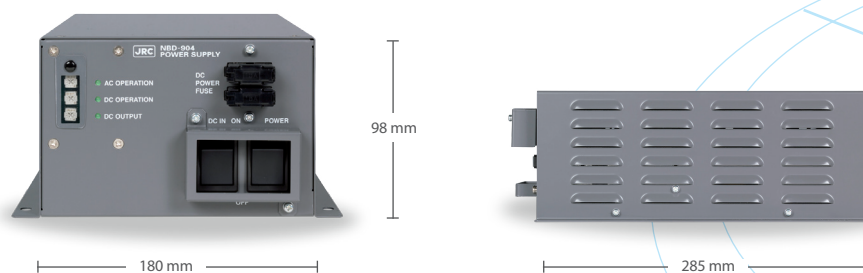

Specifications

JUE-501	
Inmarsat type approved	✓
RoHS	✓
Frequency New	Transmit 1626.5–1660.5 MHz, 1668.0–1675.0 MHz receive 1518.0–1559.0 MHz
Voice/fax	4 kbps voice, G3 fax
Data	Streaming IP: 8, 16, 32, 64, 128, 256 kbps, standard IP: 432 kbps, SMS: 3G (up to 160 characters)
Antenna type	54 cm flat diameter, 3 axis control system, GFRP enclosure
Beam width	22° in 3dB direction
Power	21.6–31.2V DC (optional PSU 90–264V AC)
Consumption	Less than 180W
Power output PoE New	Up to 15.4W per port (total 32W max)
Antenna environmental	Infrared: 500W/m ² , ultraviolet: 54W/m ² , icing 25mm, precipitation: 100mm/hr, wind: 100kn
Ship's motion	Roll: ±30°/8 sec, pitch: ±10°/6 sec, yaw: ±8°/50 sec, surge: ±0.2g, sway: ±0.2g, heave: ±0.5g, rate of turn (ROT): ±6°/sec, headway: 30kn
E.I.R.P.	+22dBW +1/-2dB (class 8)
G/T	-7.0dB (class 8)
Handset	1 port (main unit)
RJ11 telephone/fax	2 ports (main unit), 4 ports (optional junction board)
LAN	6 ports (main unit) 1 port: JRC LAN, 1 port: EXT WAN, 4 ports: free use and support PoE
ISDN	1 port for 3.1k audio only (INS/ETSI) (main unit)
External GPS input	IEC61162-1 (optional junction board)
GPS output	Via LAN
External gyro input ¹	1 port (optional junction board)
WRF output	1 port (main unit)
External buzzer	4 ports (optional junction board)
Distress button New	1 port (main unit), 1 port (optional junction board) for non SOLAS distress
Antenna connector	1 port - TNC female (main unit)
External in/out	Alarm output via JRC LAN (main unit), remote power switch control, incoming call output, incoming call acknowledge input (optional junction board)
SIM card	1 slot with protective cover (main unit)
Ambient conditions	Operating temperature: -25° to 55°C (antenna) -15° to 55°C (main unit, handset) Storage temperature: -40° to 80°C IP protection rate: IP56 (antenna), IP22 (main unit), IPX0 (handset) Relative humidity: 0% to 95% non-condensing

1. Gyro interface required when gyro signal is SYNC or STEP

JRC in Europe/Africa

Cessnalaan 40-42
1119 NL Schiphol-Rijk
The Netherlands

T +31 20 658 0750
F +31 20 658 0755
W jrceurope.com

JRC in Asia/Oceania

Fujisawa bldg. 30-16
Ogikubo 4-chome Sugunami-ku
Tokyo 167-8540, Japan

T +81 3 6832 1721
F +81 3 6832 1845
W jrc.co.jp

JRC in the Americas

1011 SW Klickitat Way, B-201
Seattle, WA 98134
USA

T +1 206 654 5644
F +1 206 654 7030
W jrcafrica.com

NAVTEAM

Professional Marine Electronics

NAVTEAM A/S
Norgesvej 7
DK-5700 Svendborg - Denmark
Phone: + 45 63 21 80 80
sales@navteam.com
www.navteam.com